

**Accumulator-driven
suction frame
ADK V 600**

Suction frame for mobile use

- ◆ Accumulator-driven and self-contained manipulator to handle glass panes or similar plates
- ◆ Stepless tilting by hand-operated hydraulic
- ◆ Manual endless rotation
- ◆ 2-circuit-vacuum system according to European norm EN 13155
- ◆ Own weight: only 50 kg



Application possibilities

Position of suction cups and connectors can be modified variously and very easily by socket pins (without tools)

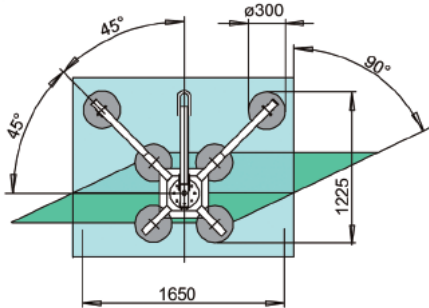

As suction bar for narrow panes

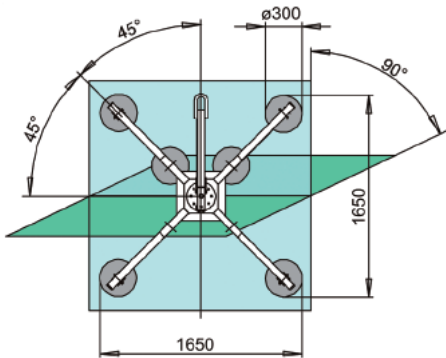

With connectors for large panes

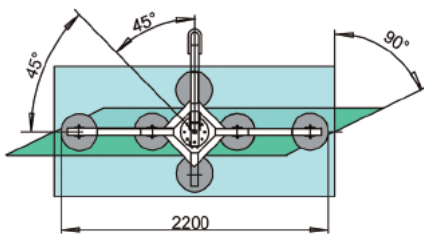

As suction bar for narrow panes

Technical data

| | |
|-----------------------------|---|
| Application | self-contained in chain or wire rope hoist, in hall or mobile crane |
| Safe working load | 600 daN (kg) |
| Rotation of load | manually, endless locking per 45° |
| Tilting of load | 0–90° by hand-operated hydraulic |
| Suction cups | 6 x Ø 300 mm |
| Vacuum generation | vacuum pump |
| Own weight | 50 kg |
| Battery | 2 V / 7,2 Ah, approx. 150 x sucking |
| Battery charger | 230 V |
| Dimensions of suction frame | variable, by combinations of connectors and suction cups |
| Standard colour | white aluminium RAL 9006 |
| Safety device | visual indicator |

Supplementary equipment

Transport box to receive ADK and accessories



Transport truck to receive ADK and accessories

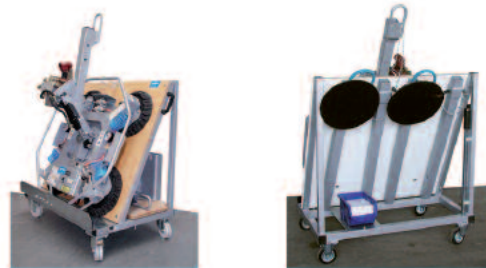

Fixing device for fork-lift truck



Extra suspension (exchangeable) which enables the use of the ADK for facade glazing between the scaffolding and the facade of the building

